

# QUICK START GUIDE (NT538 ETH INSTALLATION NOTES)

## RULES FOR THE CORRECT INSTALLATION OF THE NT538 ETH CONTROL UNIT

In order to guarantee the correct and reliable operation of the transformer temperature control system, follow the instructions supplied in this document about the installation of the control unit and the connection of the temperature sensors.

### SAFETY REQUIREMENTS

#### ATTENTION:

Read the manual carefully before starting to use the control unit. Keep the instructions for future reference.

Do not open the device, touching any internal components can cause electric shock. Contact with voltage over 50 Volts can be fatal. To reduce the risk of electric shock, do not dismantle the back of the device for any reason. Moreover its opening would void the warranty.

Before connecting the device to the power supply, make sure that all the connections are correct. Always disconnect the unit from the supply before any cabling modification.

Any work on the equipment must be entrusted to a qualified engineer.

Failure to comply with these instructions can cause damages, fires or electric shock, and possible serious injuries!

### POWER SUPPLY

The NT538 ETH has UNIVERSAL power supply, i.e. it can be supplied by 85 to 260 Vac-Vdc, irrespectively of polarity in Vdc.

Before using it, make sure the power cable is not damaged, knotted or pinched. Do not tamper with the power cable. Never disconnect the unit by pulling the cable, avoid touching the pins. Do not carry out any connecting/disconnecting with wet hands. To disconnect the device, do not use objects such as levers. Immediately disconnect the device if you smell burning or see any smoke: contact technical service.

### LIQUIDS

Do not expose the equipment to splashes or drops, do not position it in places with humidity exceeding 90% and never touch with wet or humid hands during storms. If any liquid penetrates the control unit, disconnect it immediately and contact technical service.

### CLEANING

Disconnect the power cable before cleaning the control unit, use a dry cloth to dust it, without any solvent or detergents, and compressed air.

### OBJECTS

Never insert any objects into the cracks of the control unit. If this happens, disconnect the control unit and contact an engineer.

### USE RESERVED TO QUALIFIED PERSONNEL

The purchased goods are a sophisticated electronic device that is totally unsuitable to be used by non-qualified personnel. Any work must be carried out by a specialist engineer.

### ACCESSORIES

The use of non-original accessories or spare parts can damage the unit and endanger users' safety. In the event of faults, contact technical service.

### LOCATION

Install the control unit indoors, in a place protected from water splashes and sun rays. Do not place near heat sources exceeding the parameters stated in this manual. Position on a stable surface, far from any possible vibrations. Position the unit as far as possible from any intense magnetic fields.

### REPAIRS

Do not open the control unit. For any fault, always use qualified personnel. The opening of the control unit and/or the removal of the series identifying label entails the automatic forfeiture of the warranty. The Warranty seal is applied to all devices, any attempt to open the unit would break the seal and cause the consequent automatic forfeiture of the warranty.

### FUNCTION

To control the transformer correctly from a temperature point of view, enabling the VOTING function is allowed where the load distributed between the phases of the transformer is adequately balanced.

### FITTING THE CONTROL UNIT

The temperature control unit must be fitted on a panel complying with the following instructions:

- The device is designed to be panel-mounted.
- Do not position the device near any heat sources or strong magnetic fields.
- Operating temperature from -20°C to 60°C
- Maximum humidity 90% (non-condensing)
- Indoor work environment (protected by splashes and sun rays)
- Make a 92 x 92mm hole (tolerance +0.8mm) in the panel metal sheet.

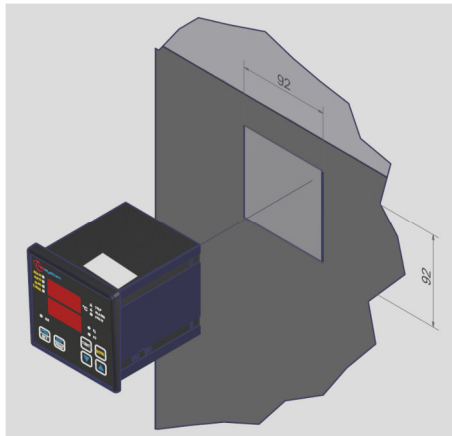

Fix the unit securely with the blocks supplied.

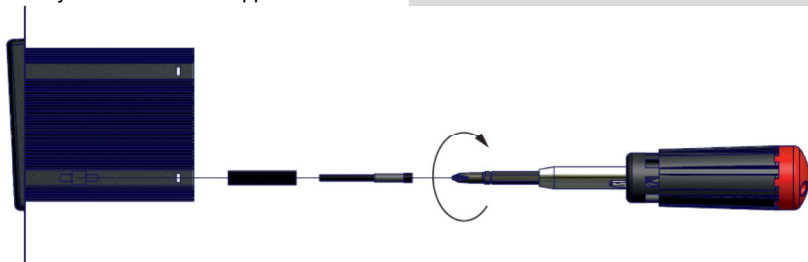

## ELECTRICAL CONNECTIONS

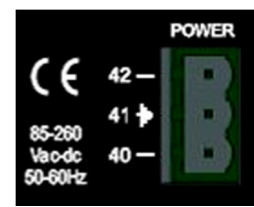
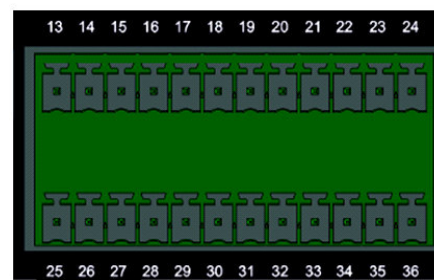

The NT538 ETH control unit has **UNIVERSAL POWER SUPPLY** it can be supplied by **85 to 260 Vac-Vdc, 50/60Hz** irrespectively of polarity in Vdc (terminals 40-42). The ground must always be connected to terminal 41.



**SENSORS.** 8 inputs for RTD sensors, Pt100 type with 3 wires (max section 1.5mm<sup>2</sup>).

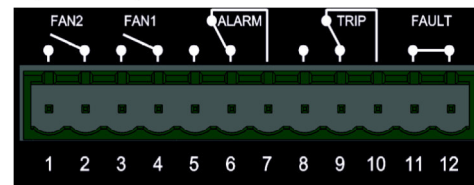

**RELAYS.** Output relay with 10A-250Vac-res COSΦ=1 contacts.

Ethernet 10Base -T / 100Base - TX , full TCP / IP stack , suited to work as a Modbus TCP slave. Parameters configured by default :

**IP Address: 192.168.10.120 – Gateway: 192.168.10.1 Subnet Mask: 255.255.255.0**

Led 1-2 indication :

- led 1: Link
- Off = No link
  - Amber = 10 Mbps
  - Green = 100 Mbps
- led 2: Activity
- Off = No Activity
  - Amber = Half Duplex
  - Green = Full Duplex



### CONNECTION FROM THE SCS BOX / SENSORS TO THE CONTROL UNIT

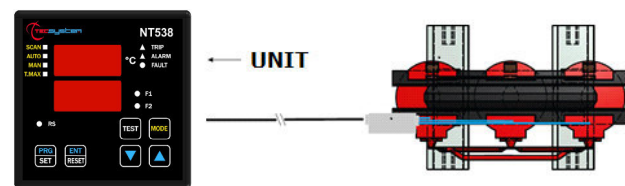

To connect the Pt100 sensors correctly between the SCS box and the temperature control unit, comply with the following instructions rigorously:

#### Installation rules:

- Every Pt100 must be connected with a three-wire cable having a minimum section of 0.35mm<sup>2</sup> and a maximum of 1 mm<sup>2</sup>.
- The extension cable must be screened with a tinned copper braid with 80% cover.
- The wires must be twisted.
- The cable screening must be grounded only with a termination, preferably on the unit side.
- The sensors' signal transfer cable must not be near any electrical cables, either low or medium-high voltage.
- The Pt100 cable and the signal transfer cable must be laid in a straight line, without any winding.
- Any caps used to butt conductors must be crimped properly to avoid false contacts.

If you do not comply with the instructions supplied, there may be anomalies in the temperature reading for which TECSYSTEM cannot be held responsible.

### DEFAULT PROGRAMMING SETTING

CH1 To CH8	ALARM CHx	TRIP CHx	HFN
YES	90°C	119°C	NO
FAN1	FAN2	FCD	VOTING
YES	YES	NO	NO
FAN1	FAN2	FSL ALARM	FLS TRIP
ON: 70°C	OFF: 60°C	ON: 45°C	OFF: 35°C
		NO	NO

#### ATTENTION:

We recommend you check the unit's programming before starting the device.

The default parameters set by TECSYSTEM might not match your requirements.

TO DOWNLOAD THE COMPLETE "NT538 ETH INSTRUCTION MANUAL", USE\* THE QR CODE ON THE CONTROL UNIT OR CONNECT TO THE TECSYSTEM WEBSITE ([www.tecssystem.it](http://www.tecssystem.it))



#### INSTRUCTION



#### MANUAL

TECHNICAL INFORMATION: Mail: [ufficiotecnico@tecssystem.it](mailto:ufficiotecnico@tecssystem.it) — tel: 02/4581861

\*download the QR CODE READER application to your smartphone / tablet and you will be ready to read all Q codes